

**IOL - Intraocular Lens**

*Pages 4-5*

**Dental Solutions**

*Pages 6-7*

**Orthopaedic Hardware**

*Pages 8-9*

**Hip Replacement**

*Pages 10-11*

**Total Knee Replacement**

*Pages 12-13*



**Medical Tools**

*Pages 14-15*

**YG-1 AND THE MEDICAL INDUSTRY**

Modern Medicine has made strides of progress in the recent decades. Part of this awe-inspiring progress is largely due to the development and implementation of advanced medical machinery, sophisticated implants and precise surgical tools. Our goal as a company is to cater to the needs of this vast industry, supporting Physicians and Surgeons world-wide. Discover the range of capabilities you'll enjoy using YG-1 tool solutions for Medical Industry.



**N** PMMA / Silicone

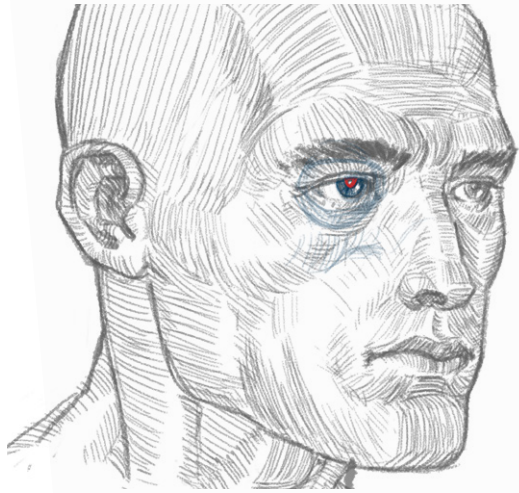

IOL, Intra-Ocular Lens are commonly implanted in the eye as a part of various medical procedures such as treatment of cataracts. IOL are made of PMMA, a material that is being superceded by silicone nowadays. Each year the number of required IOL pieces is growing, with nearly 28 million cataract procedures done in 2021 alone.

*YG-1 has developed a special miniature end mill designed to machine the lens at high precision and speed, without leaving any burrs on the finished product.*



**Special Miniature Endmill for IOL Machining**

YG-1's R&D team has developed this special tool with a tailor-made coating just for the purpose of machining Intraocular lens. Experience the quality and precision of YG-1 products, long tool life, and burr free action. YG-1 can to develop and produce various special tools, to suit your needs.



*IOL in a Special Machining Jig*





Cobalt Chromium / Titanium  
Zirconia / Glass Ceramics / Composites / PMMA / Wax

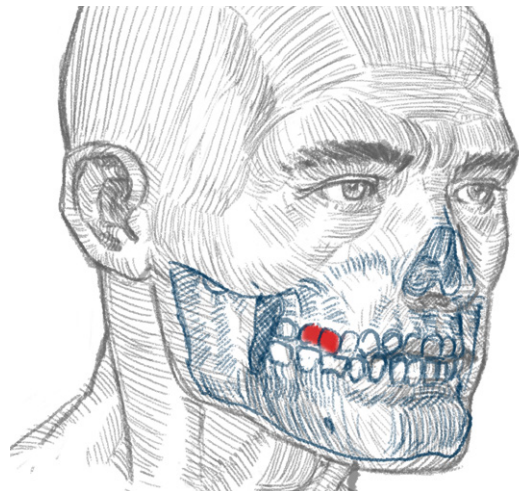

Dental surgery and implantation are very common procedures, giving birth to a vast industry of dental products. The process of dental implantation is two-fold. First, a dental screw is inserted into the bone, tooth bridges are placed. Afterwards custom shaped crown pieces are placed on top.

The dental screws and bridge pieces are made out of Titanium, while the crowns themselves are made of various materials.

Whatever the design of the components may be, YG-1 has all the necessary tools to cover all bases. Our diverse range of tools, standard and special are capable of machining complex geometries with the required level of finish on a variety of materials.



Dental and Abutment Screws  
Titanium



Different Types of Dental Pieces from Different Types of Materials



**Standard & Special Tools for Milling Dental Crowns**

YG-1 can produce and supply a wide arrangement of milling cutters for a variety of dental milling machines, from various Manufacturers. Our tools come with a wide range of standard and custom geometries, sizes, and coatings, individually, or as part of comprehensive kits for a specific machine or material. Possible materials that the tools can machine are Zirconia (ZrO<sub>2</sub>), PMMA, PEEK, Wax, Titanium Alloys, Cobalt-Chrome, Glass-Ceramics and others.

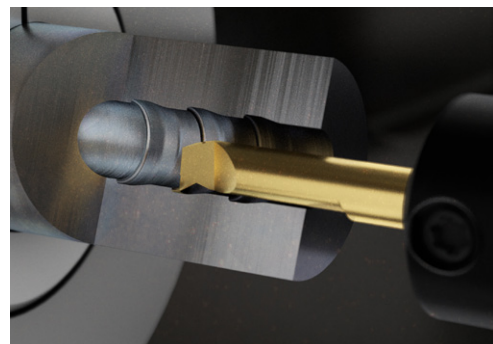

**NanoCut**

**Solid Miniature Turning**

Dental and other screws rely on precise miniature machining for success. YG-1's NanoCut line tools do exactly that, featuring various tool geometries for various Turning operations, including: Grooving, Boring, Profiling and others.



**S** Titanium

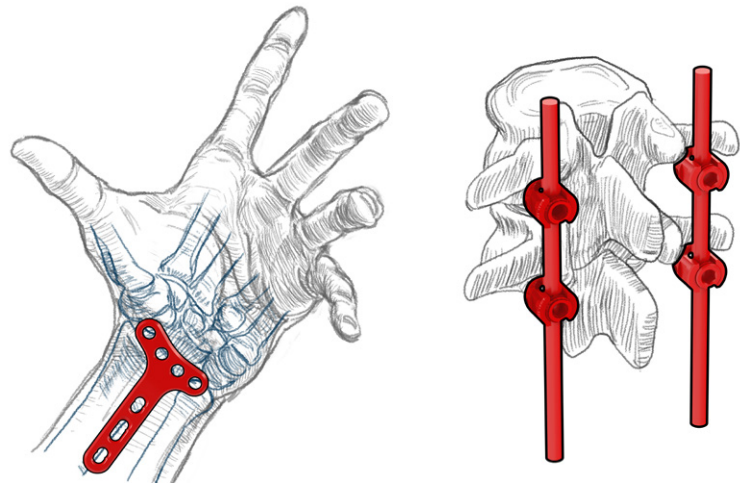

Titanium is definitely the material of choice in for the Medical Industry. It possesses the unique ability to bond with living tissue, making it an ideal candidate material for orthopedic implants such as various bone plates, pedicle screws used in spine surgeries as well as hip and knee replacements that are discussed separately in this brochure.

Titanium is also strong and lightweight. It has an increased resistance to corrosion and it is well-suited for machining provided the possession of the required tools.

Whatever the task at hand, YG-1 produces all the necessary tools for the job. YG-1 provides you a comprehensive solution for Titanium Machining.

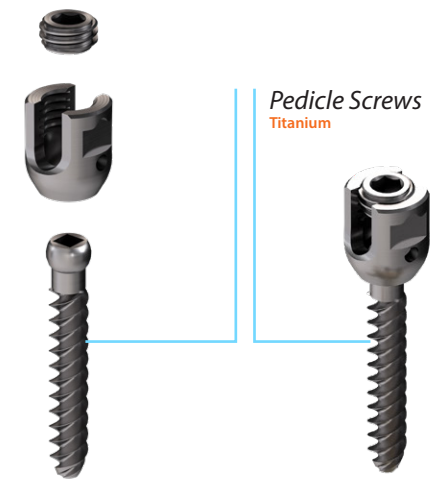

Pedicle Screws  
Titanium

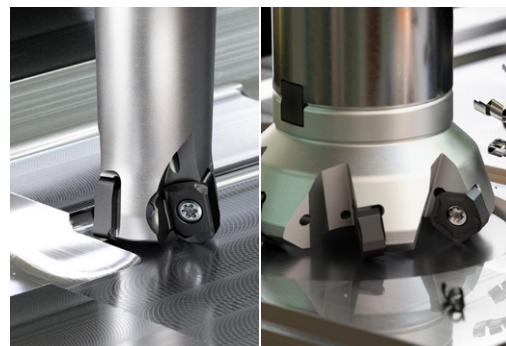
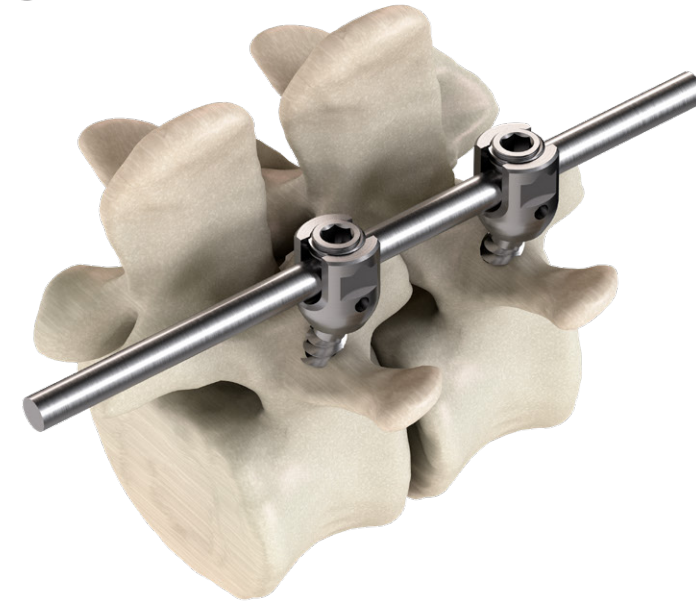

**YG MILL**

YG602 Grade M20-M40 S15-S25

YG-Mill is YG-1's line of indexable milling tools with the YG602 grade inserts suitable for machining Titanium, Cobalt-Chromium and other materials as well. Try our YG-MILL Mini High Feed line for narrow and long reach applications, or our YG-MILL with PNMU inserts for bigger application.



Wrist Plate and Orthopaedic Screws  
Titanium



Shoulder Plate  
Titanium



**N S** Cobalt Chromium / Titanium  
Ceramics / Composites

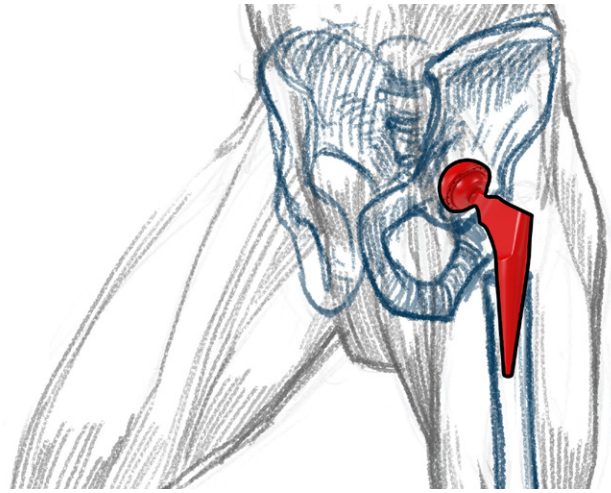

**H**ip Replacement surgery is a common medical procedure used to treat a variety of diseases and disorders. It involves the total or partial removal of the great trochanter of the femur bone, and replacing it with a prosthesis. The prosthesis is made out of three main components: The femoral stem, which is made out of either Cobalt-Chromium or Titanium; The Acetabular Cup, made of CoCr or Titanium as well; The Articular interface, or the Femoral Head which is typically made out of either the aforementioned metals or Ceramic / Composite Materials. Often, depending on the design, a liner is used between the Articular Interface and the Acetabular Cup.

The components have a variety of designs that can vary considerably from one to another. Once machined, the surfaces of the components which interface with the bone are covered with granules or metal foam and are sintered in place on the pieces.

*Whatever the design of the components may be, YG-1 has all the necessary tools that cover all bases. Our diverse range of tools, standard and special are capable of machining the complex geometries with the required level of finish on a variety of materials.*



**Special Drills for Titanium**

Just like any other tools, designing drills for Titanium requires a specific approach and know-how. Know-how that YG-1 certainly possesses! Our extensive knowledge and manufacturing abilities enable us to make drills for Titanium, standard (including flat-bottom) & special geometries, along with variety of coating solutions for Titanium.

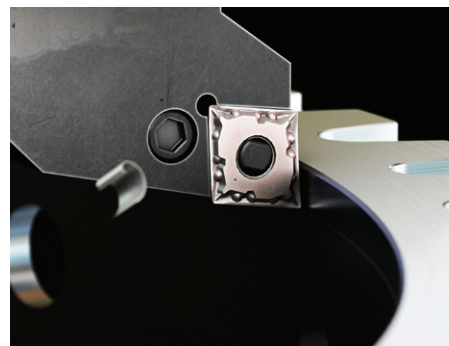

**YGTURN**

**YG401 Grade S10-S20**

The premier indexable grade for HRSA Materials, especially Titanium. Comes in a variety of Insert design with a range of chipbreaker geometries. YG401 is perfect for machining medical components.

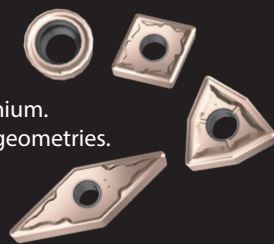

**TitaNox Power & TitaNox Power HPC**

TitaNox-Power End Mills are our premier go-to solution for machining Titanium. Featuring several cutting edge geometries, 4 and 5 flute designs, and variable helix and pitch. Try our industry leading Solid Carbide endmills designed to meet any challenge!



**S** Titanium

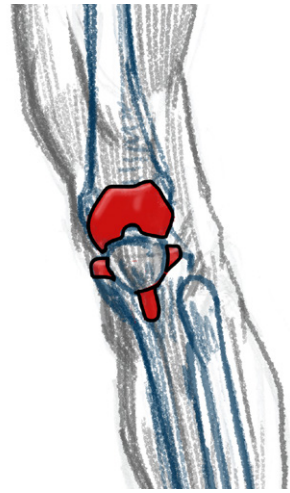

As is the case with the hip joint, so is the knee can require replacement surgery. Knee Replacement, also known as Knee Arthroplasty requires specialized tools and implements, as well as a custom made replacement components which are all made out of Titanium alloys.

To the right are examples of various tools and components used in a typical knee replacement procedure. As you can see, some of the components have quite complex geometry, requiring an array of machine tools specifically for titanium, to produce.

For the various Titanium-made implements, tools and replacement components of the knee, YG-1 has a great range of solutions.



**Special High-Feed Solid Tools**

Try our specially designed solid carbide high-feed tools for high productivity rates in conventional and 5-axis CNC milling centers machines. These tools are coated with our proprietary coating for efficient heat removal and prolonged tool life.

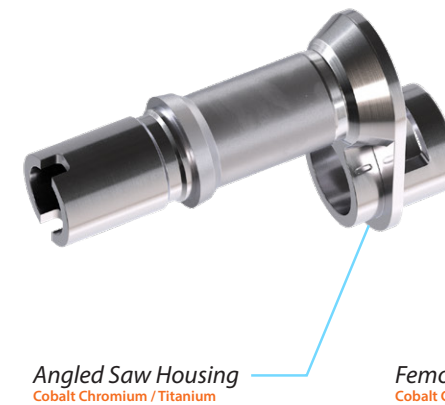
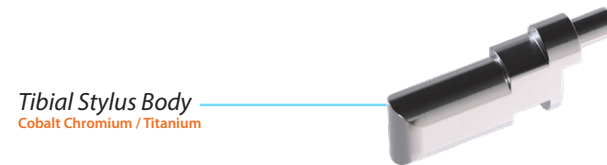

**X5070 & X1-EH Premium New End Mill**

Our Blue-coated **X5070** End Mills have an outstanding reputation worldwide! With a wide range of geometries and sizes, **X5070** is ready to tackle any demanding task. **X5070** is designed to mill hard materials (HRc 50-70).

**X1-EH** is a New C-coated Nano Grain Solid Carbide End Mill. It has the Next Performance Level within hard materials like HRc50 above with exceptional highly accurate micro tooling and it can make it an ideal choice for precision milling.



**Specially Designed Tools for PH Material and Titanium**

YG-1 can develop and bring to the customer individualized products according to their needs and preferences. Standard tools along with special geometries, coatings, and other features are available upon request.





**Surgical Grade Stainless Steel [ 316 / 440 / 420 / 17-4 / 15-5 / 13-8 and others ]  
Composites**

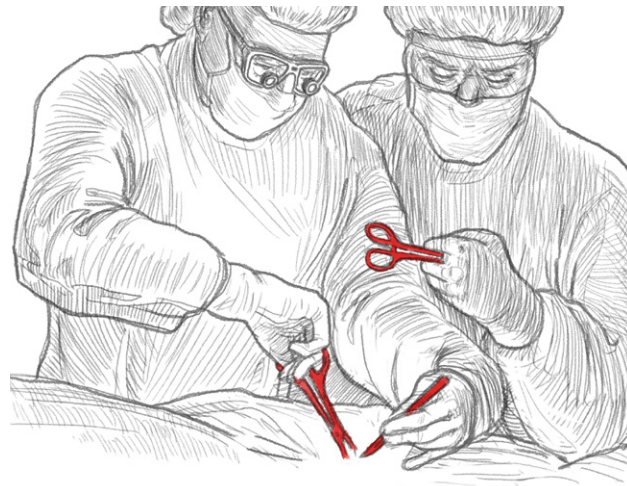

**M**edical tools and machinery are an indispensable part of the modern clinics and hospitals. While sophisticated state-of-the-art equipment is becoming more ubiquitous by the day, the days of the simple tools, such as a needle, scissors, and a sharp blade of a scalpel are far from over. Together, the two will continue to be a common sight into the foreseeable future.

*We at YG-1 understand the needs of the modern medical industry and the incredible products this industry produces. Part of this understanding, is not neglecting the need to design tools for the manufacture of hand-held surgical tools as well as the needs of medical machinery manufacturers. Whatever the product, big or small, sophisticated or simple, we got you covered.*



**V7 Plus**

Hand held surgical tools, such as shown in the picture above, are made out of high grade surgical stainless steel. Machining stainless steel is no easy matter, but our **V7 Plus** range of tools with special 7 flutes are more than capable of doing just so. Featuring various geometries suitable for slotting, profiling, and side-cutting, and our Y-Coating.

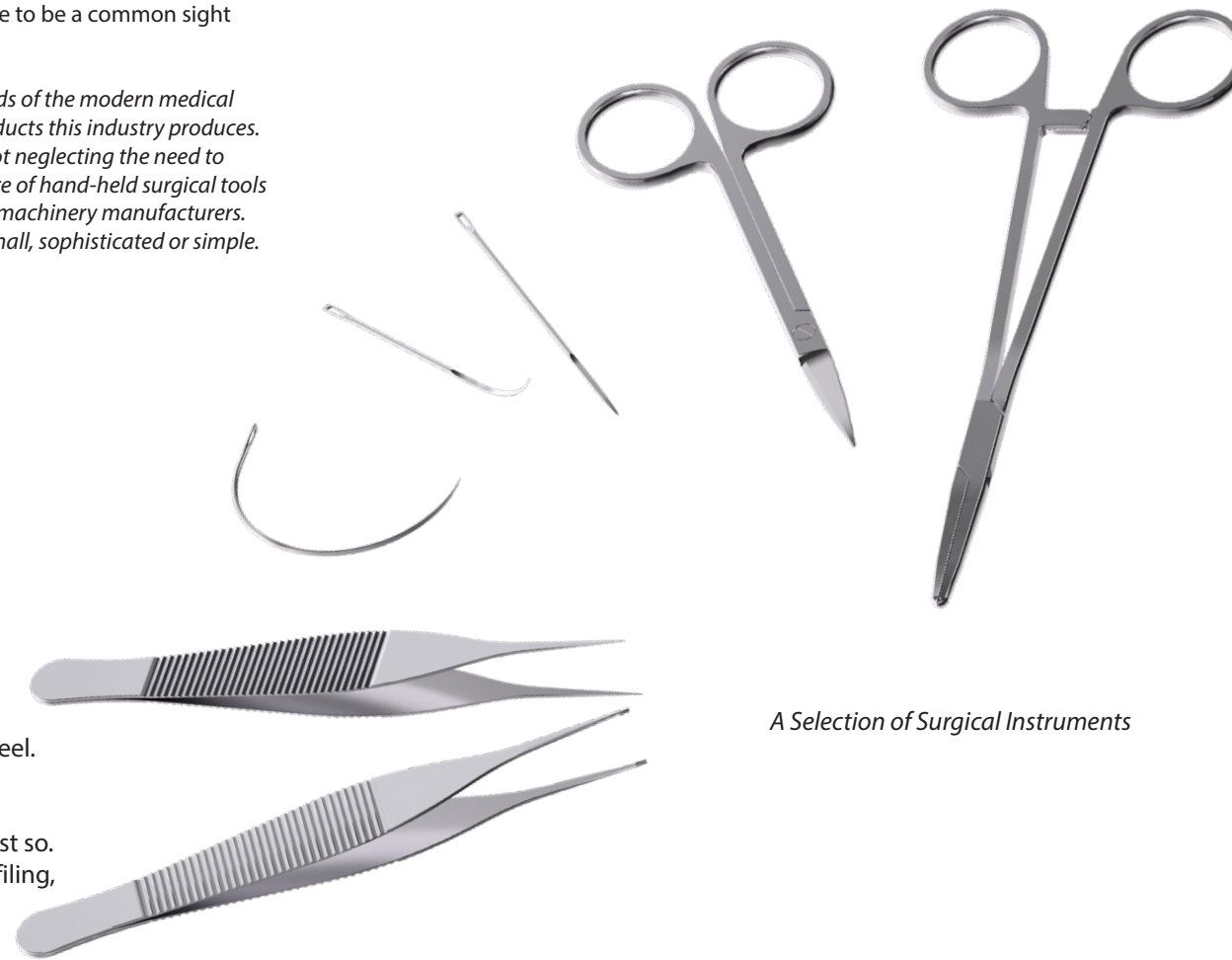

*A Selection of Surgical Instruments*

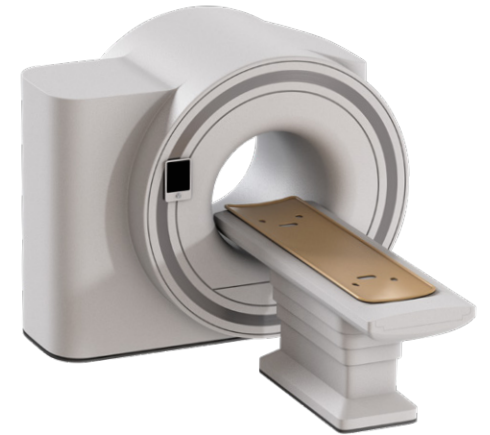

**Medical Machinery**

These days medical machinery plays an ever-growing and essential role in a variety of medical procedures, surgeries, and diagnostic screenings. A good example is the MRI machine shown above, which is used to get accurate medical imagery of the patient's organs.

Medical machinery is constructed using plastic polymers, but increasingly out of composite materials, that require specialized tools to the machine.

YG-1 has all your needs covered in these areas!

Please check our **COMPOSITE MATERIALS** brochure, available on YG-1 Website to find solutions for this industry.



Scan to QR Code for **COMPOSITE MATERIALS** brochure



**DREAM DRILL Series**

YG-1 has an entire portfolio of high-performance drills, featuring various application and material specific geometries and a variety of coatings. Try our **DREAM DRILL INOX** line of drills which are specifically designed to machine stainless steel. **DREAM DRILL FLAT BOTTOM** is the go-to tool when a flat bottom hole is required. And finally, our state-of-the-art **DREAM DRILL HIGH FEED** product line featuring 3-flute high-performance drills with H-coating.

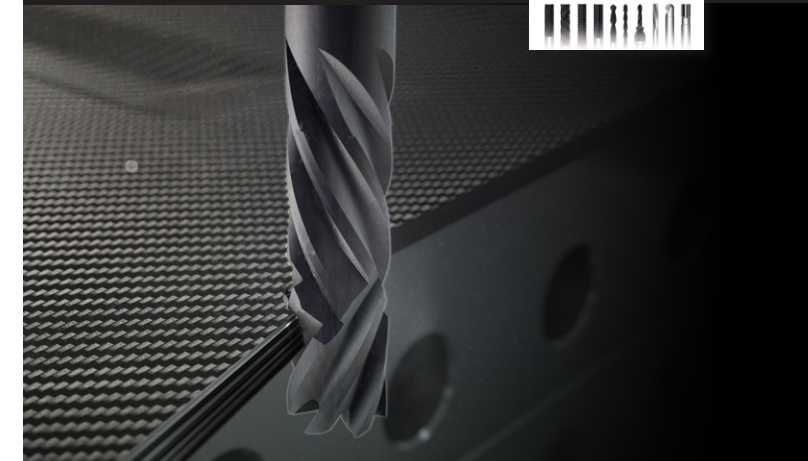
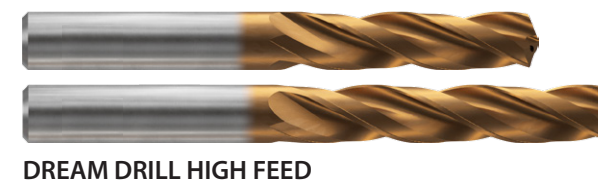
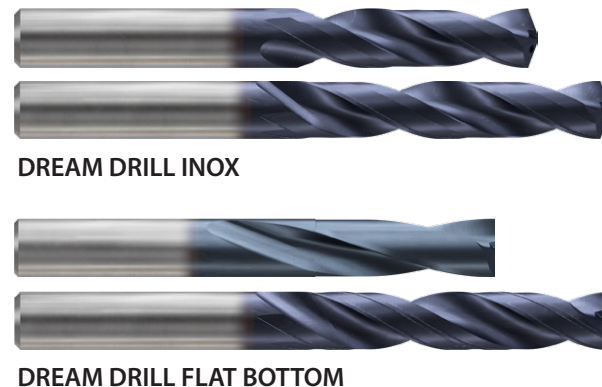



# YG GLOBAL TECH CENTERS

BRING US YOUR DESIGN CONCEPTS, YOUR SMALL BATCH RUNS, AND YOUR FULL-BLOWN PRODUCTION NEEDS



## Value Performance Engineering

- Engineered for reliability and consistency in performance
- Complete understanding of demand requirements
- Optimized for the most cost-effective solution
- Best cost-per-part value

## Designed to Accommodate Your Needs

- Capabilities for small-batch production
- Ready access to world-class engineering
- Complete re-sharpening services
- Fast turnaround for one-of-a-kind tools and solutions

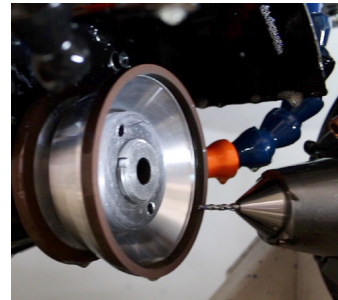
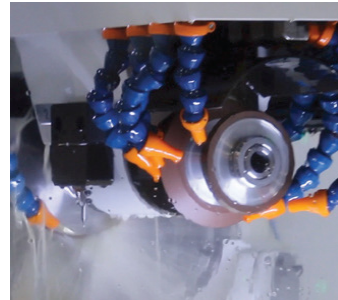

## COLLABORATION IS KEY

From your first design concepts to prototyping to final tooling, YG-1 will work with you at every turn. It's this partnership that keeps our customers on the cutting edge with the most cost-effective tooling solutions in the industry. For group training, collaboration with our designers and engineers, the Tech Center features an expansive training room with a live demonstration area.



## INDUSTRY SOLUTIONS BROCHURES

YG-1 has many more industry solutions for you! Automotive, Aerospace, Composite Materials, Die & Mold, and many more to come. Whichever industry area you're coming from, YG-1 has the solution for you. Check what we have for you at the following web link:  
[https://www.yg1.kr/support/milling.asp?r\\_b\\_ex1=Industries](https://www.yg1.kr/support/milling.asp?r_b_ex1=Industries)

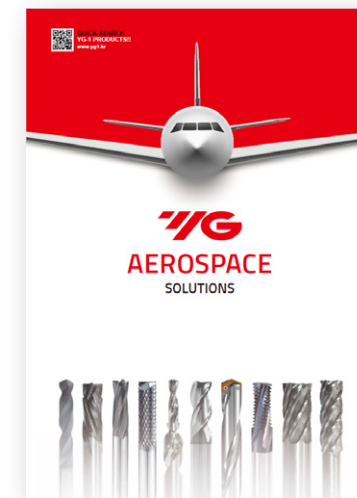



# GLOBALLY POSITIONED TECHNOLOGY CENTERS

YG-1 has met the challenges and developed the newest cutting materials and coatings for years. In addition, it offers the best technical support and expert support directly to the end customer with globally positioned technology centers.

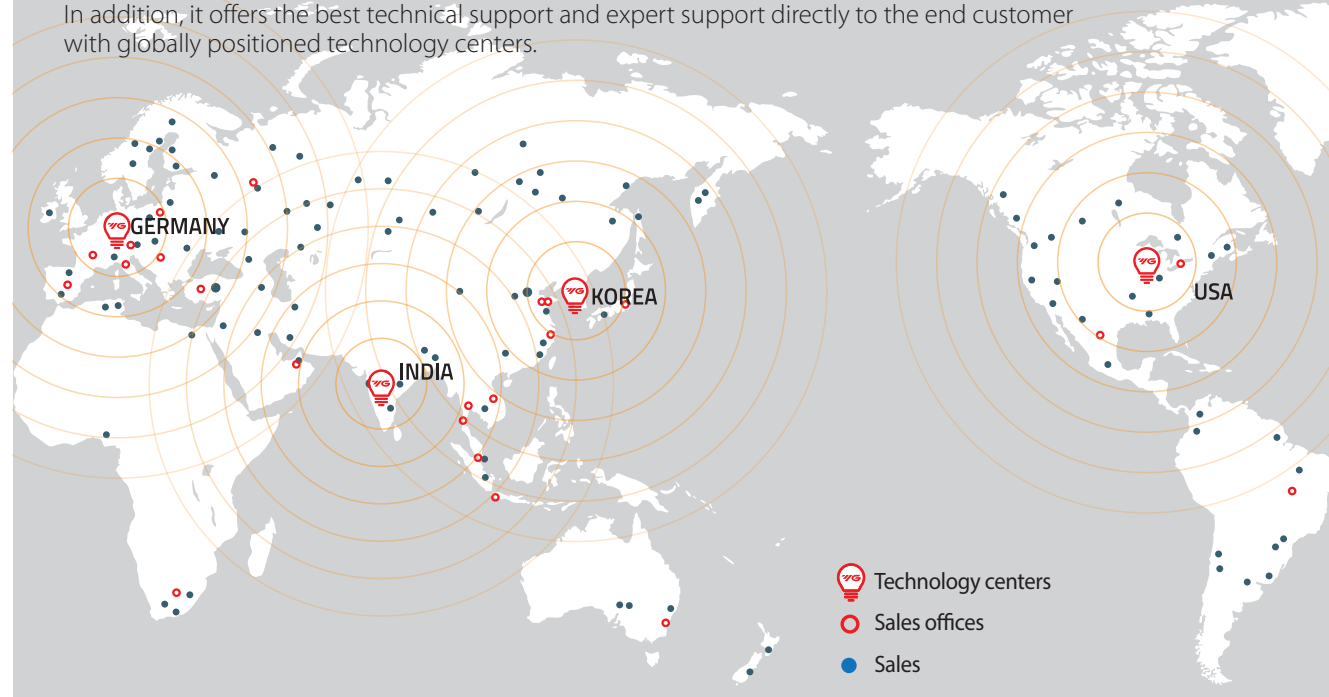

## HIGH QUALITY PRODUCTS and ON TIME DELIVERY for WORLD-WIDE CUSTOMERS

Since 1982, YG-1 has been committed to quality, innovation and the unique customer experience. Our performance and experience have granted YG-1 the global impression of one of the leading manufacturers of high quality cutting tool solutions. This global footprint expands over 75 countries, with international logistic centers, pledging to our customers to give the best service available today - and tomorrow.

### EUROPE

- |                |                        |           |             |                |                 |
|----------------|------------------------|-----------|-------------|----------------|-----------------|
| BELGIUM        | FINLAND                | ITALY     | PORTUGAL    | SLOVENIA       | THE NETHERLANDS |
| CROATIA        | FRANCE                 | LITHUANIA | ROMANIA     | SPAIN          | TÜRKIYE         |
| CZECH REPUBLIC | GERMANY                | NORWAY    | SWEDEN      | UNITED KINGDOM | DENMARK         |
| HUNGARY        | POLAND                 | SERBIA    | SWITZERLAND | AUSTRIA        | GREECE          |
| ALBANIA        | BOSNIA AND HERZEGOVINA | UKRAINE   | UZBEKISTAN  | BULGARIA       |                 |
| ESTONIA        |                        |           |             |                |                 |

### ASIA PACIFIC

- |           |              |             |                      |         |
|-----------|--------------|-------------|----------------------|---------|
| AUSTRALIA | INDONESIA    | MALAYSIA    | SOUTH KOREA          | VIETNAM |
| CHINA     | ISRAEL       | PAKISTAN    | TAIWAN               |         |
| HONG KONG | JAPAN        | PHILIPPINES | THAILAND             |         |
| INDIA     | SAUDI ARABIA | SINGAPORE   | UNITED ARAB EMIRATES |         |

### AMERICAS

- |        |        |          |        |               |
|--------|--------|----------|--------|---------------|
| BRAZIL | CANADA | COLOMBIA | MEXICO | UNITED STATES |
|--------|--------|----------|--------|---------------|

### AFRICA

- |       |              |
|-------|--------------|
| EGYPT | SOUTH AFRICA |
|-------|--------------|

## DESIGN, SIMULATE, PRODUCE AND TEST IN THE INDUSTRY'S MOST ADVANCED FACILITIES

### INTRODUCING THE ULTIMATE SOLUTION IN TOOL-MAKING TECHNOLOGY

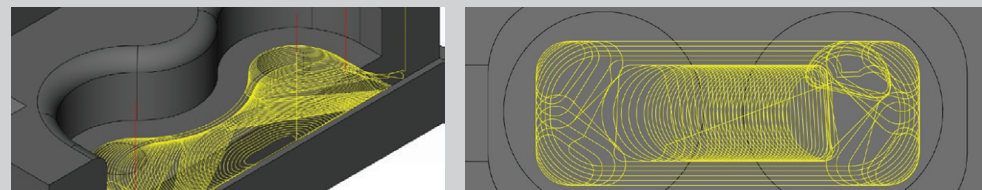

#### DESIGN

- Advanced CAD/CAM assisted application simulation to assure precise design integrity.
- On-site R & D specialists for advanced high-production solutions.
- Expertise & problem solving for the Automotive industry as well as other industries.
- Designing our products to meet the needs of the client each time.

#### SIMULATE

- Computer aided simulation to assure cost-effective manufacturing.
- Machining solutions for steel, stainless steel, hard metals and non-ferrous materials.
- We can help you optimize paths for your YG-1 tools, with the help of our experts, insuring that you can get the best productivity.

#### PRODUCE

- 5-axis CNC grinding machines for rapid production.
- World-class sub micron carbide blanks to assure increased tool life.
- Latest generation in PVD and CVD coatings for enhanced wear resistance and edge protection.

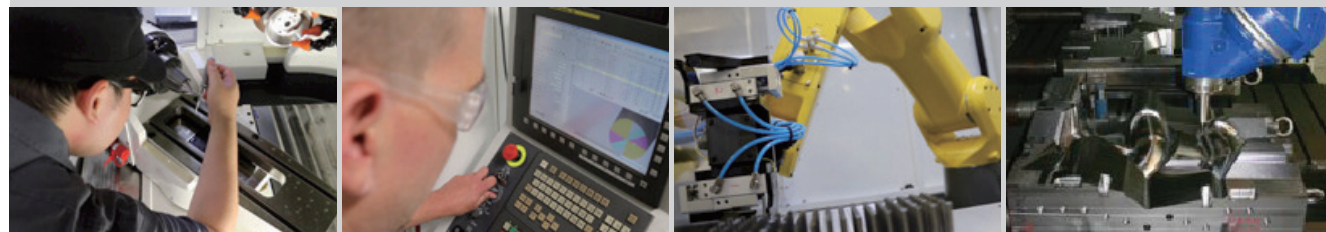

**YG-1 CO., LTD.**

\* For the more information on sales network, please contact the head office as below;

#### HEAD OFFICE

13-40, Songdogwahak-ro 16beon-gil, Yeonsu-gu, Incheon 21984, South Korea

Phone: +82-32-526-0909 <https://www.yg1.kr> E-mail: [yg1@yg1.kr](mailto:yg1@yg1.kr)